

BetaGuard® with OCTO 250 Series 1450/ 850 MOBILE ALUMINIUM TOWER Assembly Guide

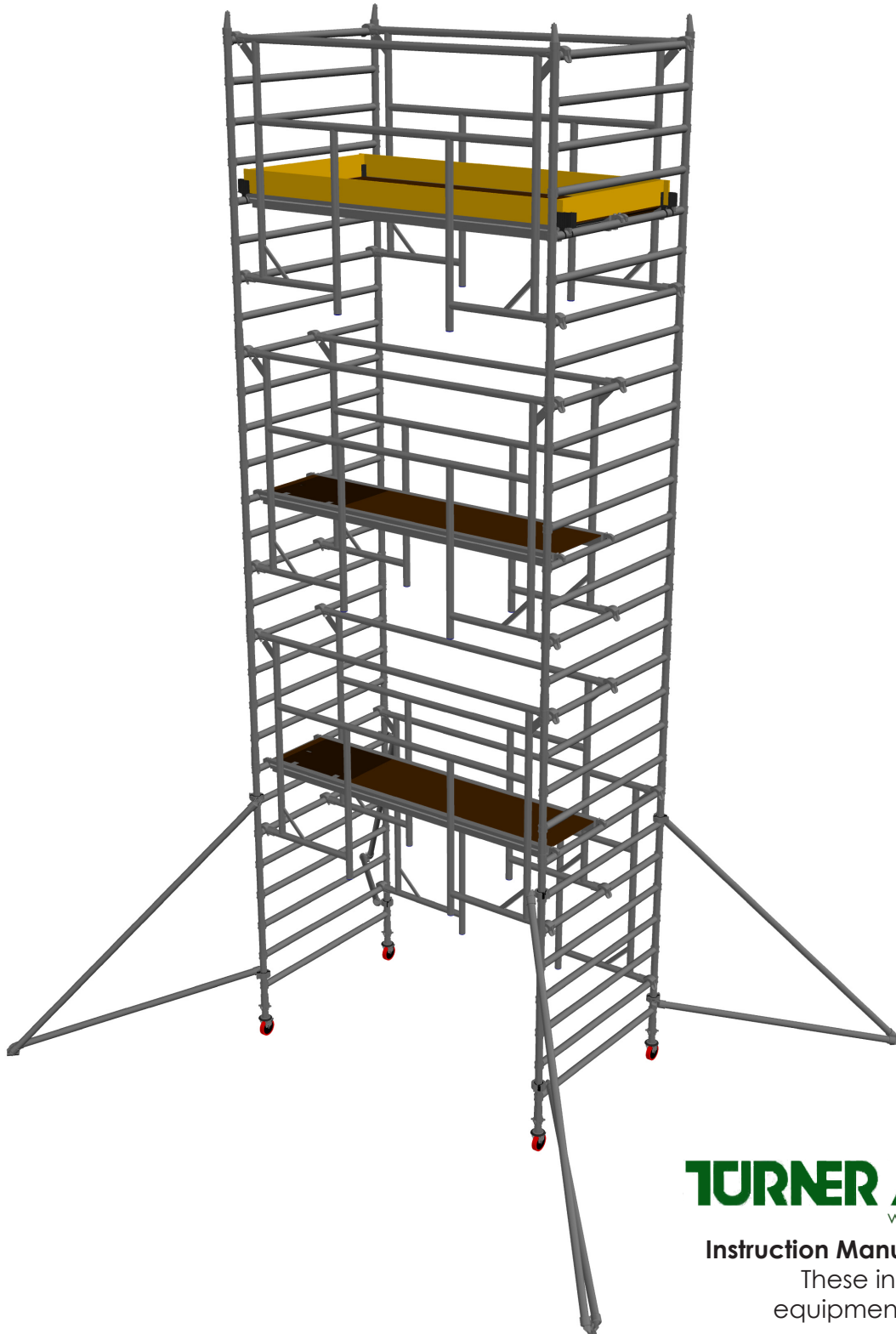

TURNER ACCESS
www.turner-access.co.uk

Instruction Manual EN 1298-IM-EN

These instructions and the
equipment described are in
accordance with

BS EN 1298 and in compliance
with **BS EN 1004:2004**

Issue 2

November 2009

INTRODUCTION

Please read this guide carefully.

The OCTO 250 Tower is a Load Class 3 tower as specified in **BS EN 1004:2004**.

This instruction manual contains all the information required to correctly assemble the OCTO 250 Tower incorporating the primary method of safe assembly of using Advanced Guardrail protection (BetaGuard®) to provide collective measures enabling full compliance with the Work at Height Regulations 2005.

The provision and utilisation of Advanced guardrail protection is recommended for all operatives erecting the OCTO 250 Tower.

This Manual should be used in conjunction with a suitable Risk Assessment and Method Statement (by user) relative to the project to be undertaken, Work at Height Regulations 2005, Regulation 6(1). It must be noted that all employers have a responsibility to ensure that work methods (practices) and adequate facilities/ resources (including work equipment) are provided to eliminate or minimise risks, Work at Height Regulations 2005, Regulations 6, 7, 8 and Schedule 3 Part 2.

Please ensure you read and fully understand the manual. Follow the content during assembly and ensure that the tower is correct and complete prior to use.

This manual must be made available to the user/ assembler at all times.

Sufficient training, combined with necessary experience, must also be considered and be appropriate to achieve competency to undertake basic mobile access tower assembly. Only competent (and qualified) personnel should undertake erection, dismantling and alteration (and organisation, planning and supervision) of basic mobile access towers, Regulation 5, the Work at Height Regulations 2005 and consideration should be given to providing additional (minimum) training beforehand, if required (Regulation 6 (5)(b)).

For Technical advice (or further information) on TURNER Towers, please contact:

Turner Access Ltd, 65 Craigton Road, Glasgow, G51 3EQ
Tel: +44 (0) 141 309 5555 Fax: +44 (0) 141 309 5436
or e mail
enquiries@turner-access.co.uk

INSPECTION, CARE AND MAINTENANCE

Handle tower components with care to avoid damage to either the person handling the equipment or the equipment itself. Components need to be firmly secured and properly supported, when being transported, to prevent damage. In long term storage, towers should be protected from the weather. Prior to use, inspect all tower components for signs of damage or defects. Damaged, defective or incorrect components must be marked as unfit for use, withdrawn from use and either repaired or destroyed. Castors and adjustable legs should be periodically lubricated to keep them free running.

SAFETY

Refer to General Safety Notes and Advice for Users.

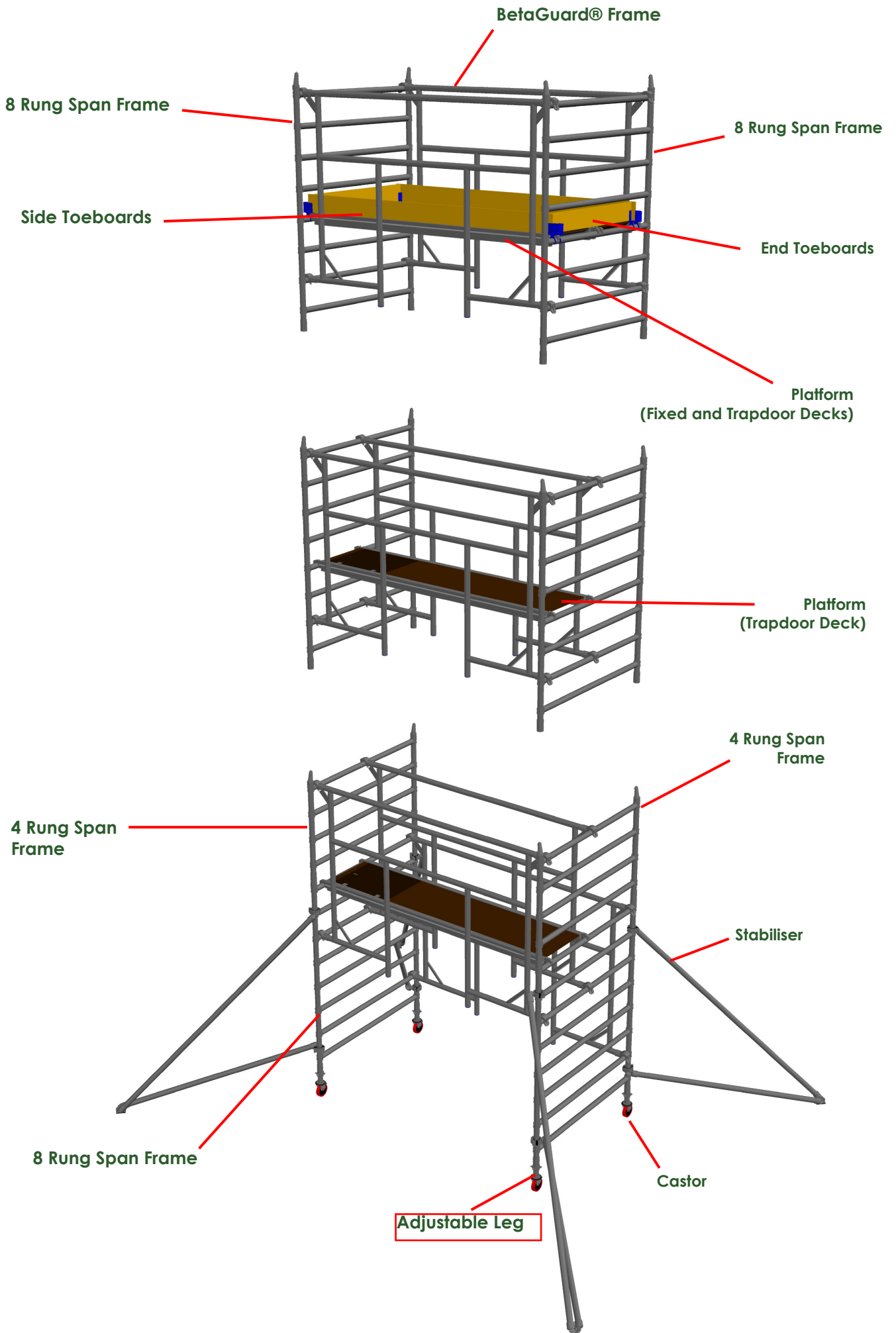

GENERAL SAFETY NOTES

1. Ensure that all necessary components and safety equipment (BetaGuard®) are available and operational.
2. Inspect the tower components for signs of damage or incorrect functioning prior to use. Damaged or incorrect components shall not be used. Castors and adjustable legs should be periodically lubricated to keep them free running.
3. Erect Exclusion zone and fit Warning Signs to comply with Schedule 3 Part 2 (11), Work at Height Regulations 2005.
4. Before erecting the tower, check that the location for the mobile access tower does not present any hazards during erection, dismantling, moving and safe working with respect to ground conditions, level and slope and obstructions.
5. Ensure the scaffolding is to be erected on suitable foundations capable of withstanding the loads imposed by the scaffolding (Schedule 3 Part 1(2) of Work at Height Regulations 2005) and, where appropriate, adequate sole boards to be provided.
6. It is recommended that at least two people erect and dismantle the tower.
7. Octo 250 tower **MUST ALWAYS** be climbed from the inside.
8. When lifting components or materials, always use reliable materials for lifting and tying methods to ensure there is no possibility of the tower overturning. Always lift from within the tower base. Ensure that the total weight of components or materials is within the maximum load per platform (300kg) and the maximum load for the overall tower (600kg).
9. Do not use hoisting arrangements on a mobile access tower.
10. The maximum wind condition for moving the mobile access tower are Beaufort Scale 0 - 4 as described in Table (Page 6).
11. Mobile access towers must only be moved manually, by pushing at the base.
Ensure that the platforms are free of persons and equipment and that brake locks are off prior to movement. Beware of soft or uneven ground and overhead obstructions.
The tower height must be reduced to 4m high and stabilisers raised approx 25mm clear of the ground.
On completing the move apply all brakes and check adjustment and stability prior to completion of tower to full assembled height.
Note Tower height must be reduced to 2m high prior to any moves if less than 4 stabilisers are used.
12. Always inspect the tower after moving and before use.
13. Always beware of live electrical apparatus, cables or moving parts of machinery.
14. Care should be taken when using power tools, wash jets or other tools that cause lateral force.
The maximum lateral force on a freestanding tower at platform level is 20kg.
15. **DO NOT** use boxes, ladders or other such means to gain additional height.
16. Never bridge between a tower and a building unless designed to a specification and approved.
17. Never jump onto platforms.
18. Fit guardrails at all platforms.
19. Fit toeboards on all working platforms.

20. Fit intermediate rest platforms at 4m intervals (maximum).
21. DO NOT affix sheeting of any type to the tower.
22. Mobile access towers are not designed to allow them to be lifted or suspended.
23. In accordance with regulations, any tower that has been erected must be inspected every 7 days (minimum) to ensure that the tower continues to comply with the regulations.

WIND SPEED SAFETY RULES

When locating the tower, check the wind conditions before erection, against the table, and beware of hazards during erection, dismantling and moving with respect to wind conditions and the funnelling effect of open ended, uncladded buildings and on building corners. Towers left unattended should be tied in to a rigid structure, especially when working outdoors or in exposed conditions. The maximum wind condition for moving the mobile access tower are Beaufort Scale 0 - 4 as described in table below.

Beaufort Scale	Description	Air speed	Action
0-4	Moderate Breeze Small Branches move	13 - 18 mph	No action required
5 - 6	Strong Breeze Large branches bend	25 - 31 mph	Tie tower to a rigid structure
>6	Walking progress impeded	34 - 40 mph	Dismantle tower if such conditions are expected

STABILISERS

Set each stabiliser at 45° (approx) for mobile access towers creating as large a footprint as possible and ensure that they are in firm contact with the ground.

Note When moving a tower the stabilisers must be raised 25mm (approx.) clear of the ground prior to the movement ensuring that on completion of the move the stabilisers are left in firm contact with the ground with all clamps fully tightened; the brakes locked and the tower stability is checked.

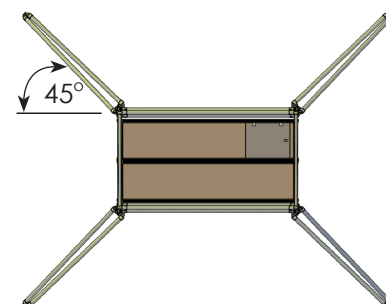

Should the tower require to be erected against a solid structure and it is not possible to set stabilisers at 45° then use either of the following alternatives

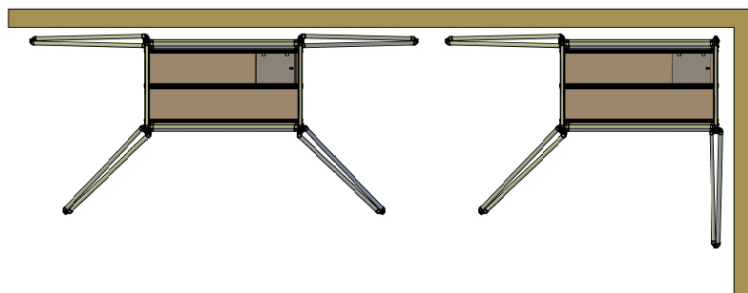

Larger stabilisers can be used at lower level to improve stability, if required.

TIES

If the safe tower height exceeds that as detailed in the Quantity schedule or the optimum base dimension cannot be constructed or other such factors that may affect the tower stability then, it will be necessary to rigidly tie the tower into an adjacent structure, using tubes and couplers suitable for coupling to the tower that has tube diameter of 50.8mm.

BetaGuard® FRAME

All BetaGuard® frames are fitted with self-priming triggers that automatically lock when attached to the tower.

Attach BetaGuard® frames square to the tower and remove by releasing the lower trigger.

When attaching BetaGuard® frames the claws always face down.

When dismantling the BetaGuard® frames, it is only necessary to release the lower triggers to remove the frame from the tower.

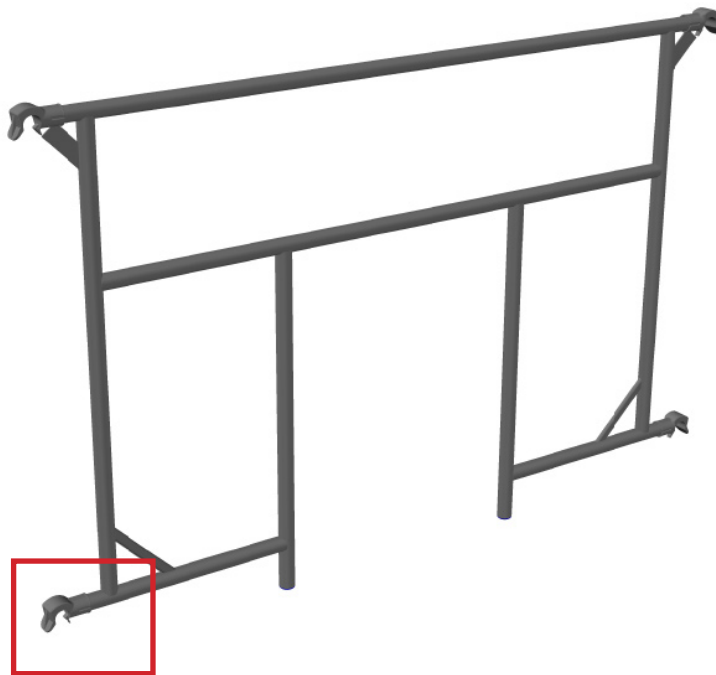

BetaGuard® Frame

Detail 'A'

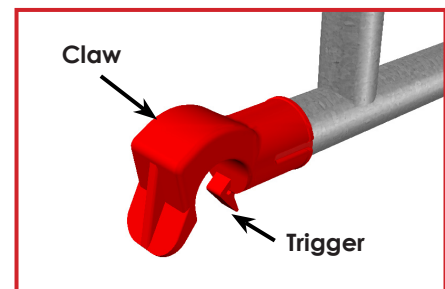

Detail 'A'

1450 Span Tower - 1.8m and 2.5m (complies with BS EN 1004:2004)

Internal/ External Use

Description	Working Height (m)	3.2	4.2	5.2	6.2	7.2	8.2	9.2	10.2	11.2	12.2	13.2	14.2
	Platform Height (m)	1.2	2.2	3.2	4.2	5.2	6.2	7.2	8.2	9.2	10.2	11.2	12.2
125/150/200mm Castor		4	4	4	4	4	4	4	4	4	4	4	4
250mm Adjustable Leg		4	4	4	4	4	4	4	4	4	4	4	4
1450 4 Rung Span Frame			2		2		2		2		2		2
1450 8 Rung Span Frame		2	2	4	4	6	6	8	8	10	10	12	12
1.5m and 2.5m Fixed Deck		1	1	1	1	1	1	1	1	1	1	1	1
1.5m and 2.5m Trap Door Deck		1	1	2	2	2	2	3	3	4	4	5	5
1.5m and 2.5m BetaGuard® Frame		2	3	4	5	6	7	8	9	10	11	12	13
1.5m and 2.5m Side Toeboard		2	2	2	2	2	2	2	2	2	2	2	2
1.45m End Toeboard		2	2	2	2	2	2	2	2	2	2	2	2
Standard Stabiliser			4	4	4	4	4						
Large Stabiliser								4	4	4	4	4	4

Maximum Safe Working Loads (S.W.L.)

300kg per platform evenly distributed.

600kg per tower evenly distributed.

The platform can consist of either one deck or two decks (placed side by side).

The load **MUST** be evenly distributed over entire platform area (whether one deck or two decks).

A maximum of 2 platform levels may be loaded.

The self weight of the tower components is not part of the 600kg S.W.L. per tower and has already been taken into account.

Note You may increase the allowable Safe Working Load to 900kg by ensuring that all even height towers have two BetaGuard® frames in the base. Please contact your supplier if you require further information.

The Quantity Schedule provides for double handrails to all platforms. Toeboards have been included to one working platform only therefore additional toeboards will have to be added to any other levels that are used as working platforms and/ or for storage of materials.

Furthermore, product standards require that towers have platforms placed at least every 4m. The Schedule exceeds this requirement.

The OCTO 250 Tower will be built safely and therefore compliance with the requirements of the Work at Height Regulations 2005 will also be met, if the schedule is followed.

Ballast: Internal/ External Use

Ballast is not required on OCTO 250 Tower if using stabilisers as detailed on Quantity Schedule.

850 Narrow width Tower - 1.8m and 2.5m (complies with BS EN 1004:2004)

Internal/ External Use

Description	Working Height (m)	3.2	4.2	5.2	6.2	7.2	8.2	9.2	10.2	11.2	12.2	13.2	14.2
	Platform Height (m)	1.2	2.2	3.2	4.2	5.2	6.2	7.2	8.2	9.2	10.2	11.2	12.2
125/150/200mm Castor		4	4	4	4	4	4	4	4	4	4	4	4
250mm Adjustable Leg		4	4	4	4	4	4	4	4	4	4	4	4
850 4 Rung Span Frame			2		2		2		2		2		2
850 8 Rung Span Frame		2	2	4	4	6	6	8	8	10	10	12	12
1.5m and 2.5m Trap Door Deck		1	1	2	2	2	2	3	3	4	4	5	5
1.5m and 2.5m BetaGuard® Frame		2	3	4	5	6	7	8	9	10	11	12	13
1.5m and 2.5m Side Toeboard		2	2	2	2	2	2	2	2	2	2	2	2
0.85m End Toeboard		2	2	2	2	2	2	2	2	2	2	2	2
Standard Stabiliser			4	4	4	4	4						
Large Stabiliser								4	4	4	4	4	4

Maximum Safe Working Loads (S.W.L.)

300kg per platform evenly distributed.

600kg per tower evenly distributed.

The load **MUST** be evenly distributed over entire platform area.

A maximum of 2 platform levels may be loaded.

The self weight of the tower components is not part of the 600kg S.W.L. per tower and has already been taken into account.

Note You may increase the allowable Safe Working Load to 900kg by ensuring that all even height towers have two BetaGuard® frames in the base. Please contact your supplier if you require further information.

The Quantity Schedule provides for double handrails to all platforms. Toeboards have been included to one working platform only therefore additional toeboards will have to be added to any other levels that are used as working platforms and/ or for storage of materials.

Furthermore, product standards require that towers have platforms placed at least every 4m. The Schedule exceeds this requirement.

The OCTO 250 Tower will be built safely and therefore compliance with the requirements of the Work at Height Regulations 2005 will also be met, if the schedule is followed.

Ballast: Internal/ External Use

Ballast is not required on OCTO 250 Tower if using stabilisers as detailed on Quantity Schedule.

DAILY CHECKS

The tower must be checked on a daily basis and after any significant weather changes e.g. high winds, snow, frost.

Use the checklist below prior to use.

- Tower is vertical and square
- Tower structure is correct and complete
- BetaGuard® correctly fitted and secure
- Castors locked/ legs correctly adjusted
- All castors, base plates and stabilisers are in contact with the ground
- Toeboards located and fixed correctly
- Correct stabilisers fitted, adjusted and secure
- Platforms locked and secure in position

If a box has not been ticked, do not use the tower until the fault is rectified.

Where a fault is found, access to the tower must be stopped.

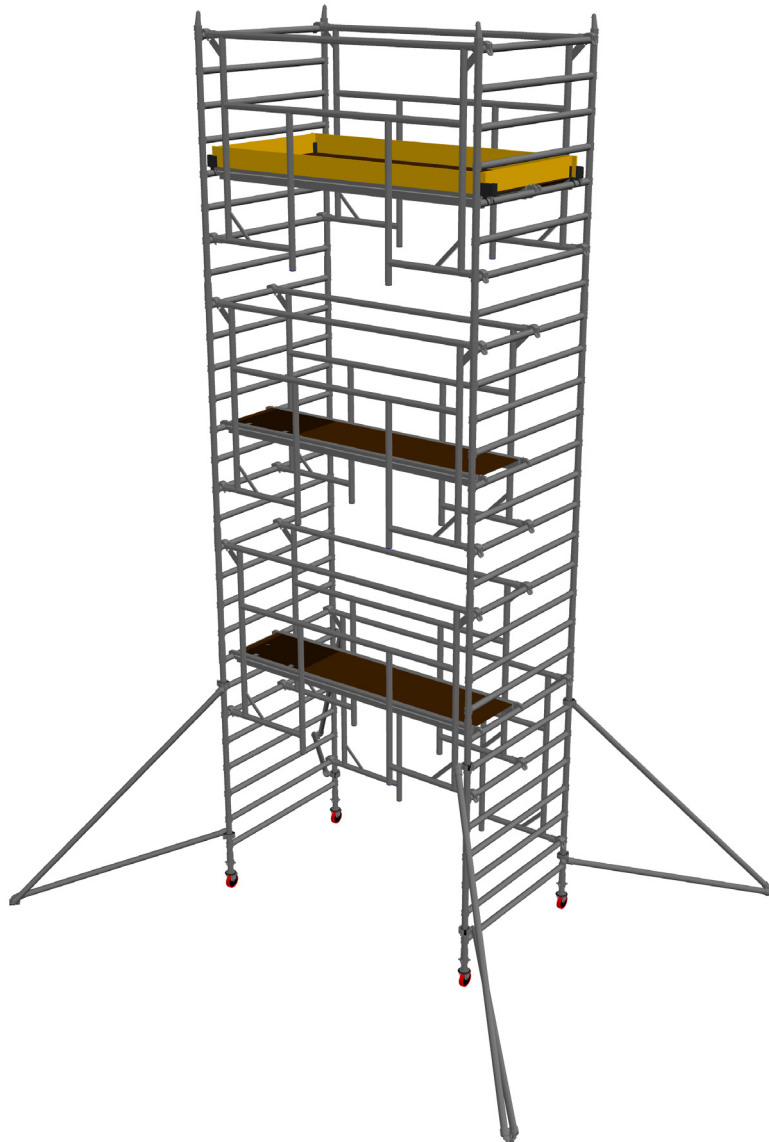

ASSEMBLY PROCEDURE 1450 TOWER

Our recommended method of assembly to fully comply with the Work at Height Regulations 2005, is by using Collective Protection which has been approved and endorsed by both PASMA and the HSE. The following assembly procedure uses BetaGuard® (Integral Advanced Guardrail).

NARROW WIDTH TOWERS

Narrow width towers are assembled following the same steps as explained for span towers, except that all platforms are trapdoor platforms.

THE BASE SECTION

1. Fit four legs to four castors (or base plates) and then turn the height adjustment collar on each leg until approximately 100mm from the lower end.
2. Set each castor brake on by moving the brake lever fully down.

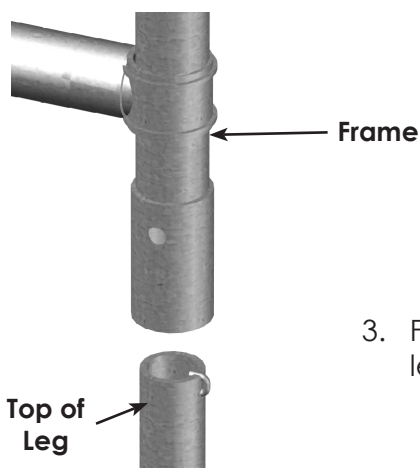
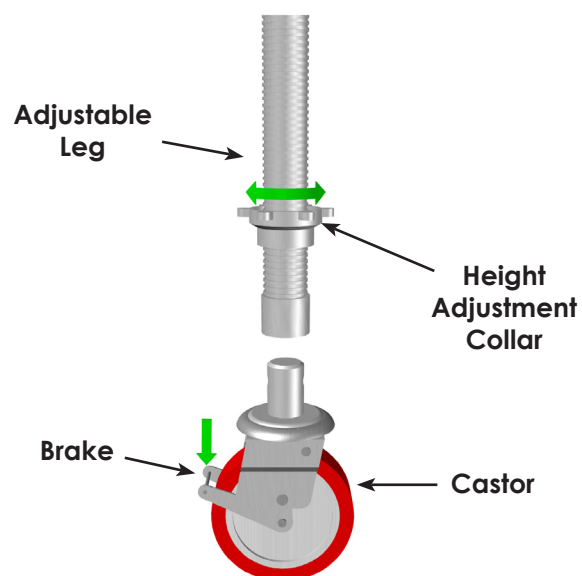

3. Fit leg assemblies to two 8 rung span frames. Insert each leg until the collar is in contact with the frame's tubing.

Steps 1 to 3 above require to be carried out for any mobile OCTO Tower using BetaGuard®.

The following sections detail the steps required to complete either the base section of an EVEN or ODD height tower

THE BASE SECTION EVEN HEIGHT TOWERS

Following on from steps 1 to 3 on previous page this section details the steps required to complete the base section of an EVEN height mobile OCTO 250 Tower using BetaGuard®.

1. Add a 1m frame to a 2m frame (using 2 operatives) ensuring frames are securely connected.

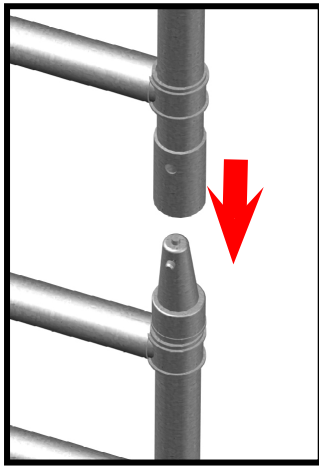

Detail 'A'

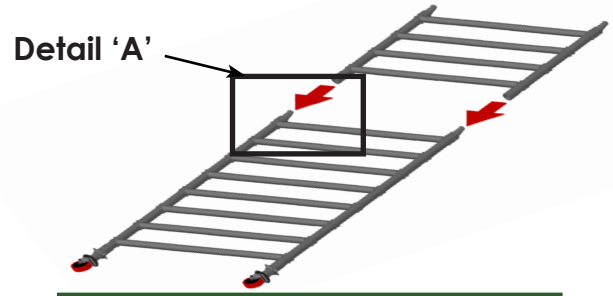

2. Raise combined frames (ensuring that castors are locked) and attach the BetaGuard® frame at 2nd and 8th rungs of lower tower frame.

Note It is recommended that 2 operatives carry out this step



3. Attach the BetaGuard® frame to the opposing tower frame and square the two frames to each other.
Note *It may be advantageous to place a platform at low level to assist in "squaring" tower.*
4. With the aid of a spirit level, you should now make any necessary adjustments to level the tower by turning the adjustment collars.



8. Add another BetaGuard® frame to the centre of the tower (approx.) at 6th rung of lower tower frame and top rung of upper tower frame, at a suitable distance apart to allow for the placing of a trapdoor platform.
9. Attach a BetaGuard® frame to outside edge (opposite existing BetaGuard® frame) at the same level as previous BetaGuard® frame .

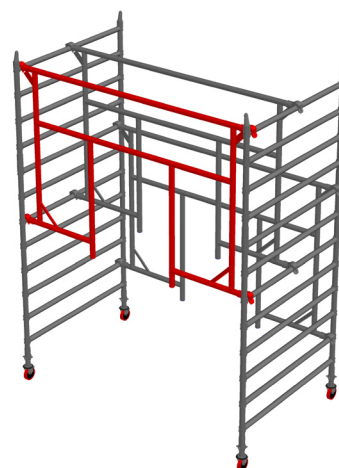

When specified, the correct stabilisers or outriggers must always be used. See Quantity Schedule.

When using standard stabilisers, fit them now (see Stabilisers section, page 14)

THE BASE SECTION ODD HEIGHT TOWERS

Following on from steps 1 to 3 on page 11, this section details the steps required to complete the base section of an ODD height mobile OCTO 250 Tower using BetaGuard®.

1. Raise frame (ensuring that castors are locked) and attach the BetaGuard® frame at 2nd and 8th rungs of tower frame.

Note It is recommended that 2 operatives carry out this step

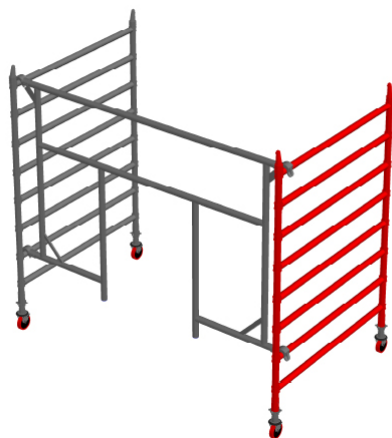

2. Attach the BetaGuard® frame to the opposing tower frame and square the two frames to each other.

Note *It may be advantageous to place a platform at low level to assist in "squaring" tower.*

3. With the aid of a spirit level, you should now make any necessary adjustments to level the tower by turning the adjustment collars.

4. Add another BetaGuard® frame to the centre of the tower (approx.) at the same level as previous BetaGuard® frame, at a suitable distance apart to allow for the placing of a trapdoor platform.

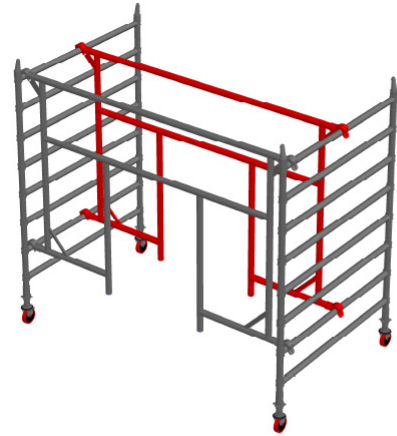

When specified, the correct stabilisers or outriggers must always be used. See Quantity Schedule.

When using standard stabilisers, fit them now.

STABILISERS

To attach the stabiliser, fit the upper screw clamp to frame upright, approx. 50mm above the seventh rung (from ground), then fit the lower screw clamp as low as possible to the frame upright.

Stabilisers should be attached so that the footprint of the tower, including stabilisers, is in accordance with the Stabilisers section shown on page 6.

Ensure that the stabilisers are in firm contact with the ground.

Notes

It may only be possible to fit large stabilisers after upper frame has been placed.

If repositioning stabilisers when in position then screw clamps MUST be loosened prior to movement then re-fixed.

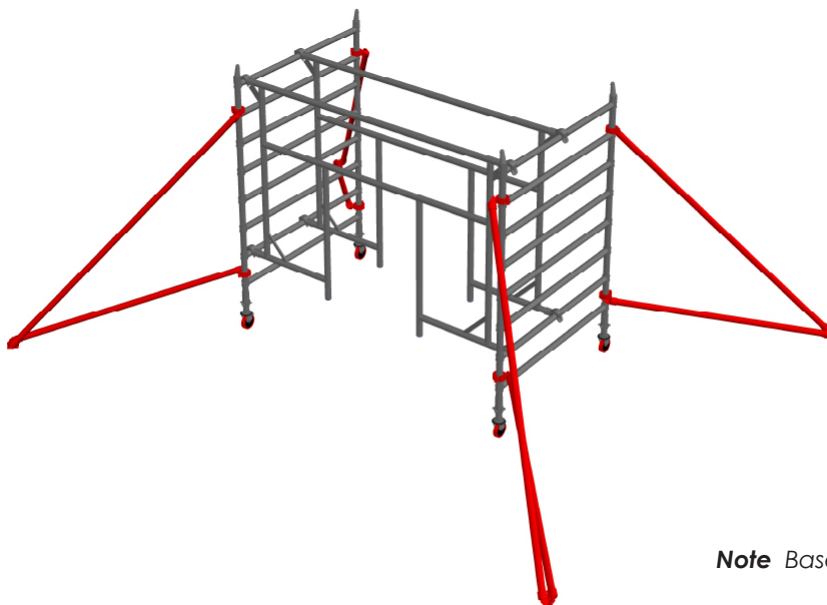
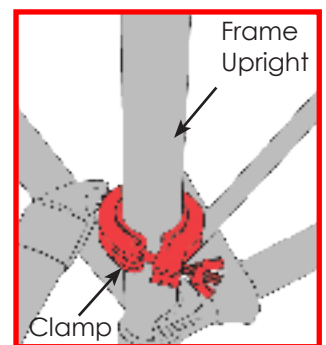

Note Base section of Odd height tower illustrated.

5. Place a trapdoor platform at the appropriate level that affords operative protection between the BetaGuard® frames.

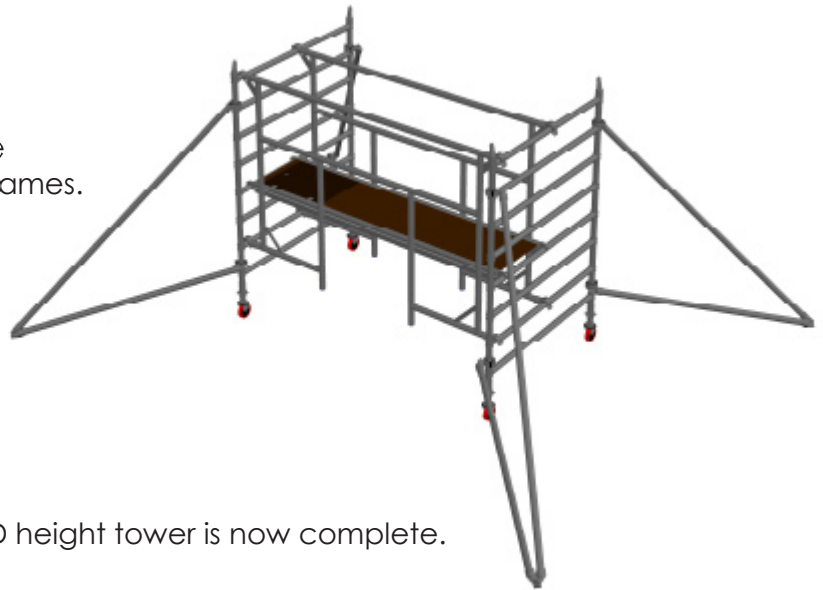

The Base Section for either an EVEN or ODD height tower is now complete.

Note Base section of Odd height tower illustrated.

ASSEMBLING UPPER FRAMES

INTERMEDIATE SECTIONS

When the base section is complete then assembly of the upper frames can commence.

Every 2m section (intermediate section) between the base section and working platform (whether ODD or EVEN height tower) is assembled using the same components and steps that follow.

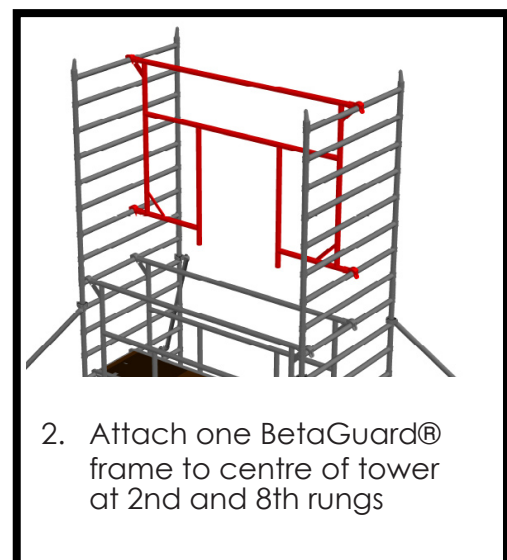
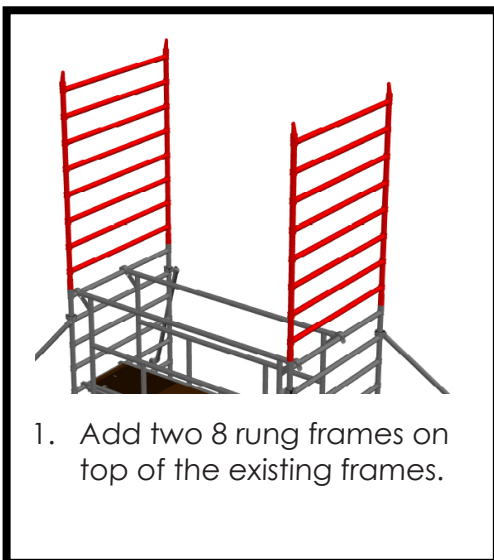

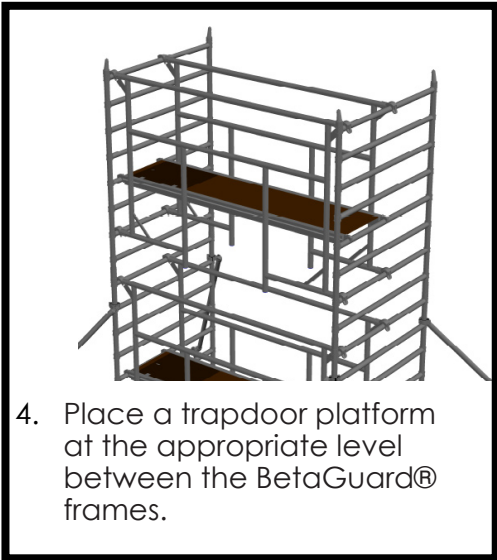
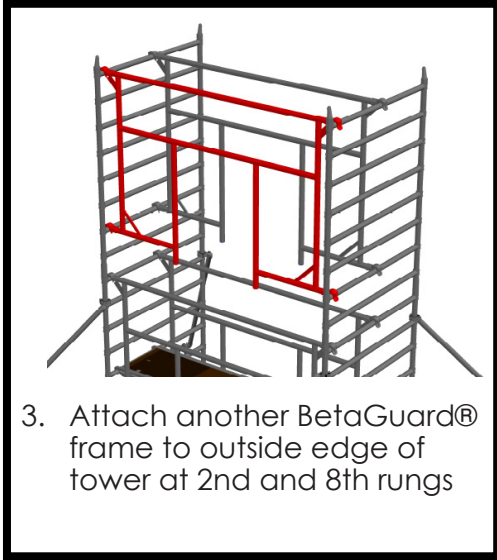

Repeat steps 1 to 4 until desired height has been reached (max. height 8m outdoors and 12 m indoors) and top platform is to be installed.

ASSEMBLING UPPER FRAMES

TOP (WORKING) PLATFORM SECTIONS

When the base section is complete then assembly of the upper frames can commence.

Every Working platform, whether it is situated at the top or between intermediate sections (ODD or EVEN height tower) is assembled using the same components and steps that follow.

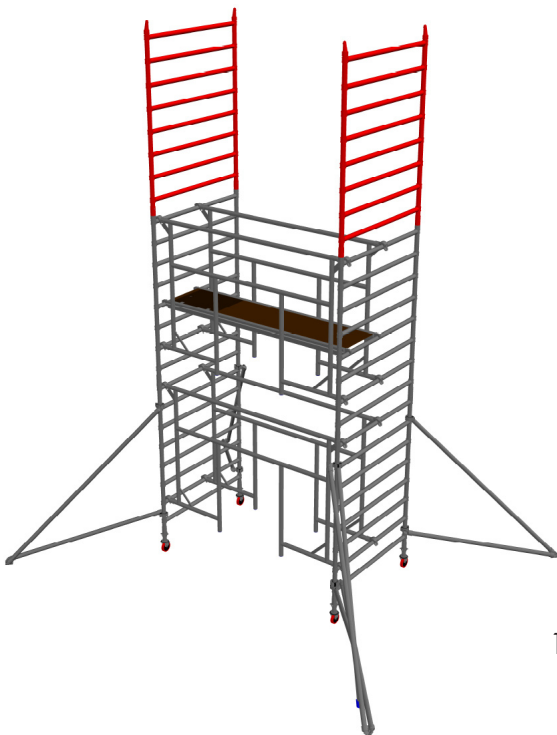

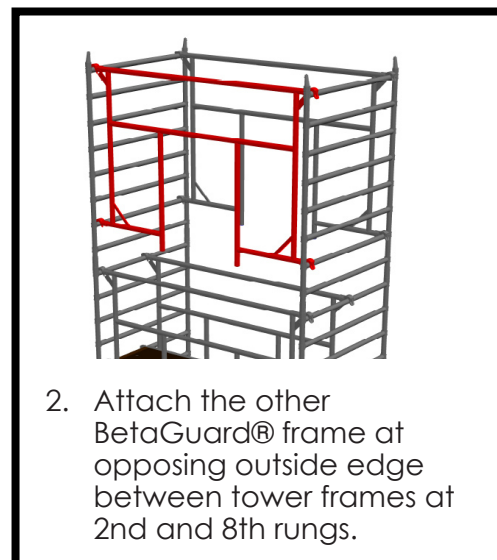
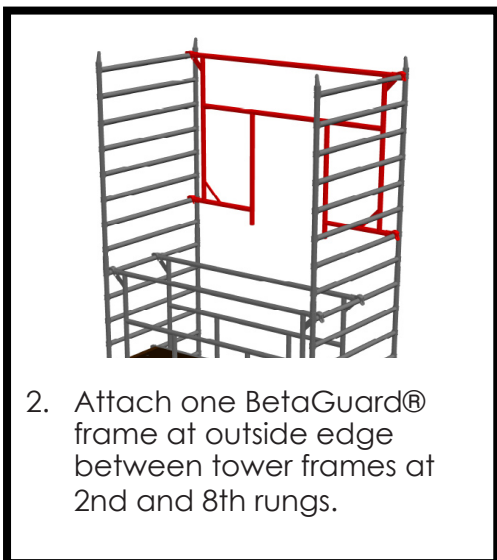

13. Place fixed platform initially at platform level and slide across to opposite side of tower, from where operative is standing below, then place trapdoor platform ensuring that trap is placed at same side to trap on platform below.

Note Ensure that the trapdoor hinge is to the outside edge.

14. Fit toeboards to all working platforms.

Scaffold is complete.

Ensure that intermediate platforms (trapdoor) are placed between BetaGuard® frames at required levels (at least every 4m).

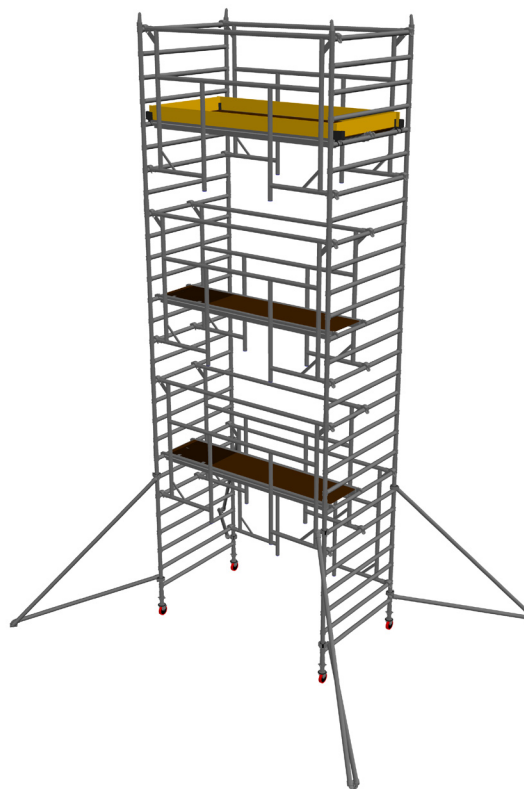

DISMANTLING THE TOWER

The dismantling procedure is simply a reversal of the steps explained for the assembly.

For your safety and that of others, take particular care not to allow components to fall to the ground since this will not only result in damage but may cause serious injury.

TRAINING

These instructions do not take the place of proper training. Consult your supplier for details of specific training courses for users of mobile access towers.

TOEBOARDS

Whichever position the working platform is assembled, toeboards must be fitted.

Slot the toeboard set together and position on the outer edge of the platform.

The toeboards are designed so that the side boards overhang the platform and the end boards are retained by raised studs on the platform hooks (see illustration).

Note If using one piece folding toeboards then select correct toeboard for the desired tower, unfold and fit in place, retained by raised studs on the platform hooks (as above).

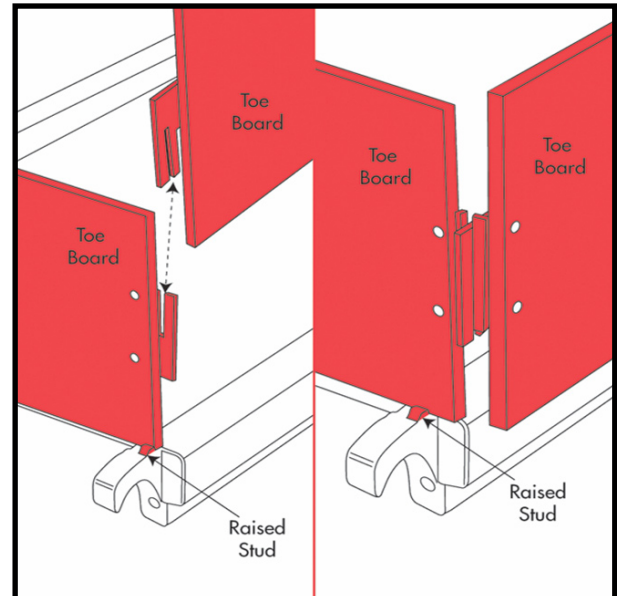

PATENT PENDING GB0813177.3

BetaGuard® is a registered Trademark of Turner Access Ltd
OCTO 250 Tower is a registered Trademark of Turner Access Ltd

NOTES



For Technical advice (or further information) on OCTO 250 Tower, please contact:
Turner Access Ltd, 65 Craigton Road, Glasgow, G51 3EQ

Tel: +44 (0) 141 309 5555 Fax: +44 (0) 141 309 5436

OCTO 250 Tower